

POWERTRAIN ELECTRIFICATION

Less a Competitor than an Enabler for the Combustion Engine ?

Günter K. Fraidl

Sr. Vice President
Passenger Car Powertrain
AVL List GmbH

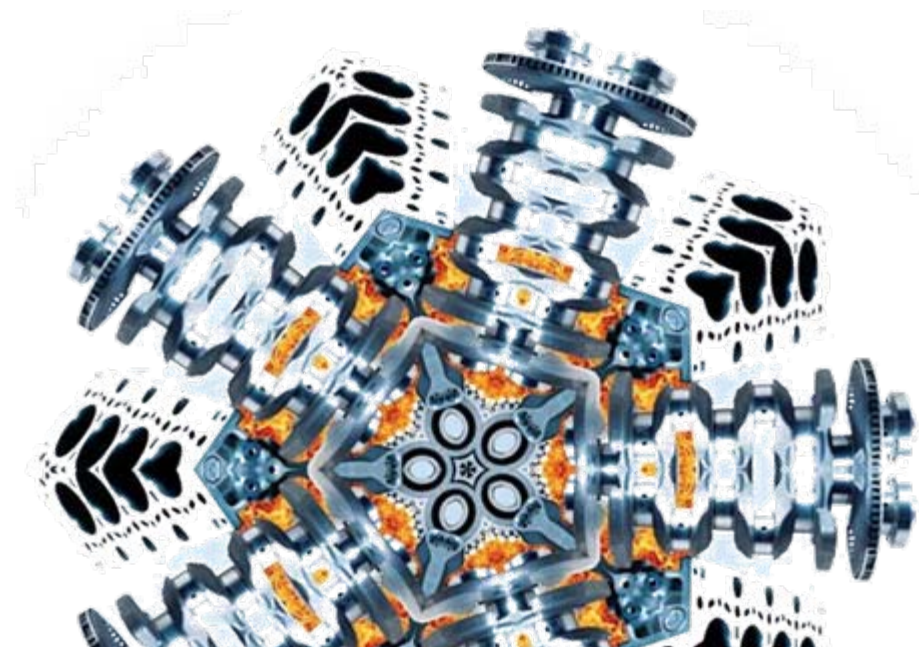

Automotive Summit
Brussels, Nov 10th, 2010

**auto
motor
and
sport**

**30.000 orders on
NISSAN Leaf**

**Does the Battery Electric Vehicle
solve the CO₂ Challenge already
short term ?**

More than 600 km range



TRANSPORT IN THE EU THE CURRENT REALTY

EU- CO₂-FLEET AVERAGE 2009

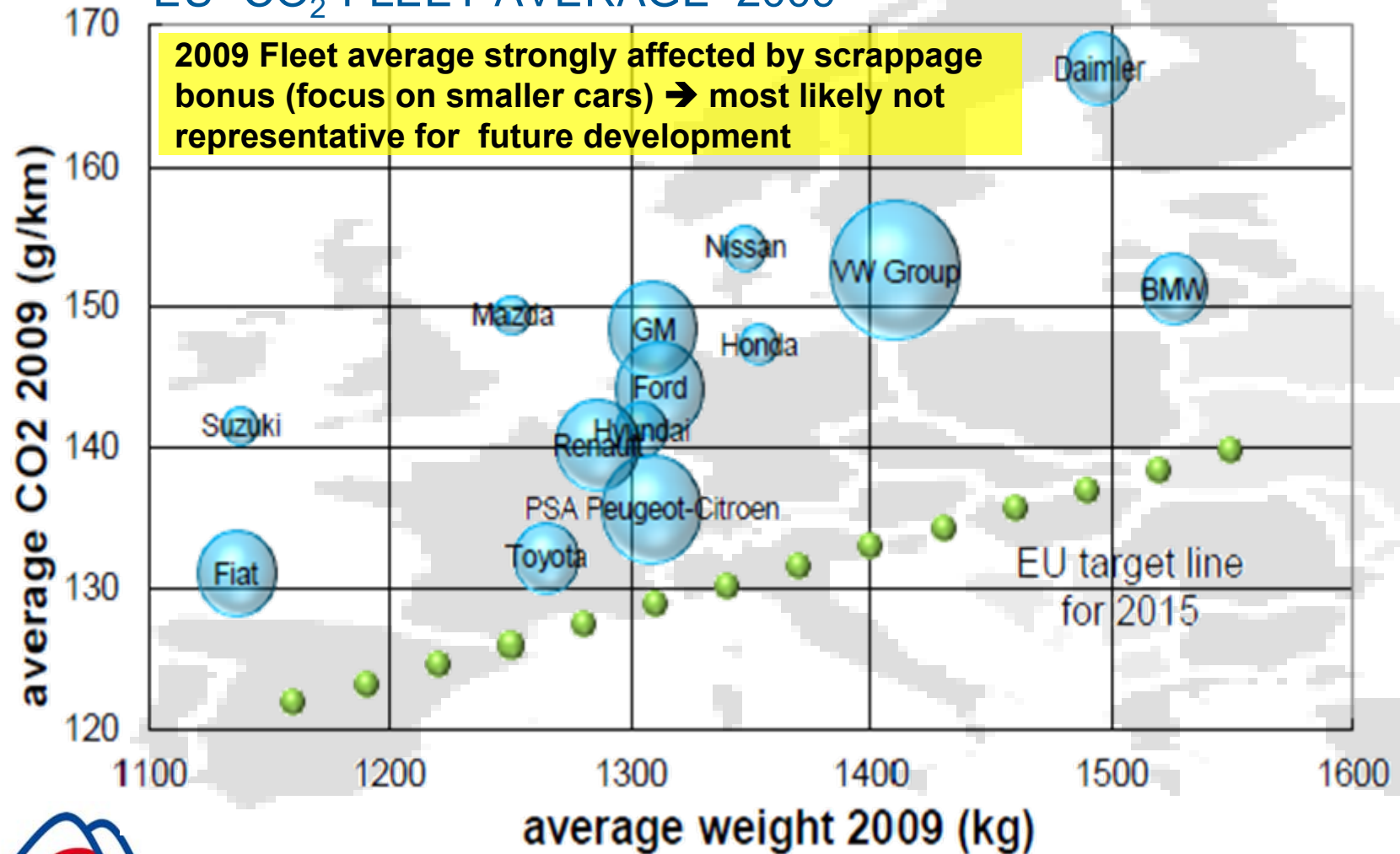

VEHICLE PRODUCTION BY PROPULSION TECHNOLOGIES

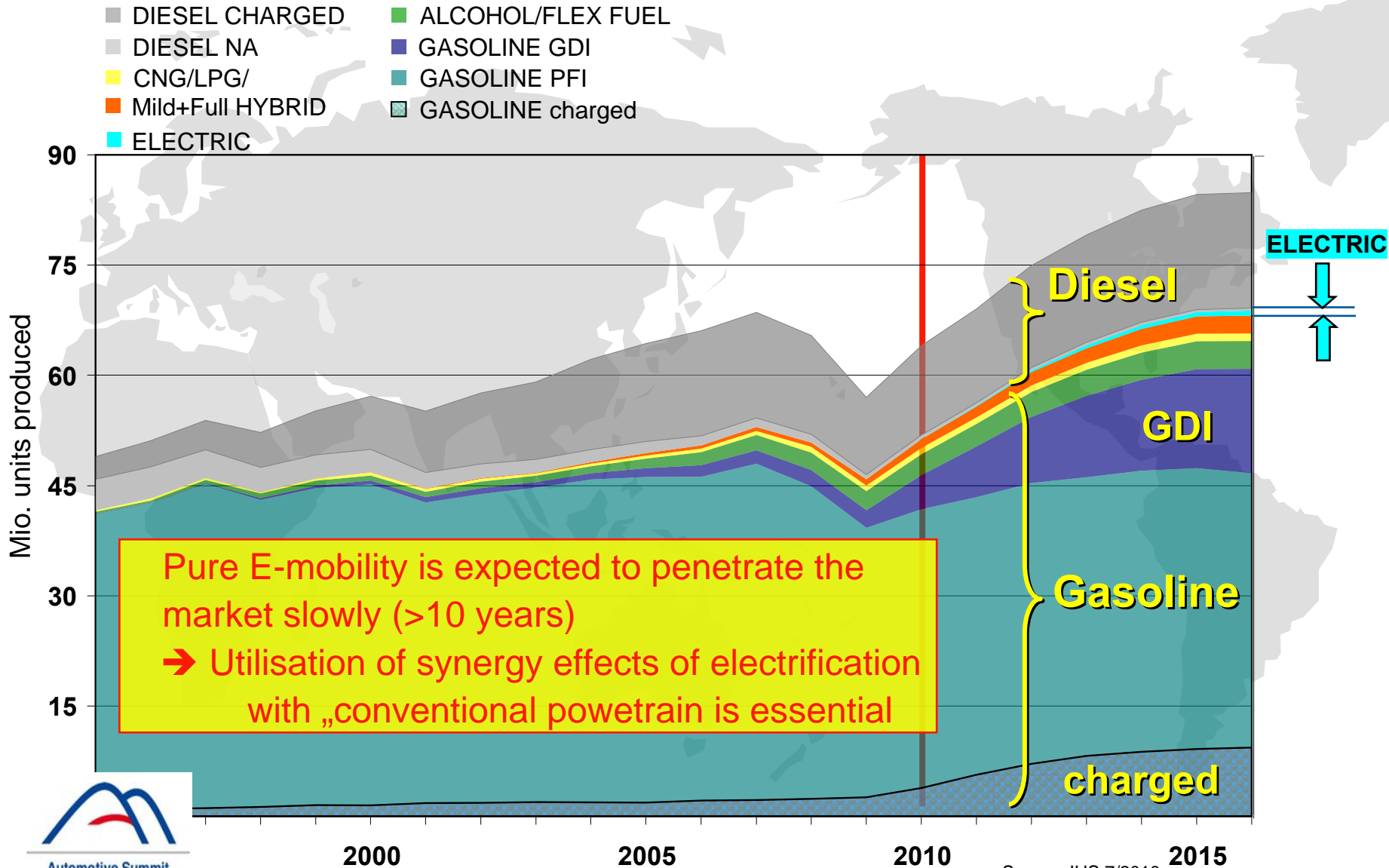

INCREASING DIVERSIFICATION OF PROPULSION SYSTEMS

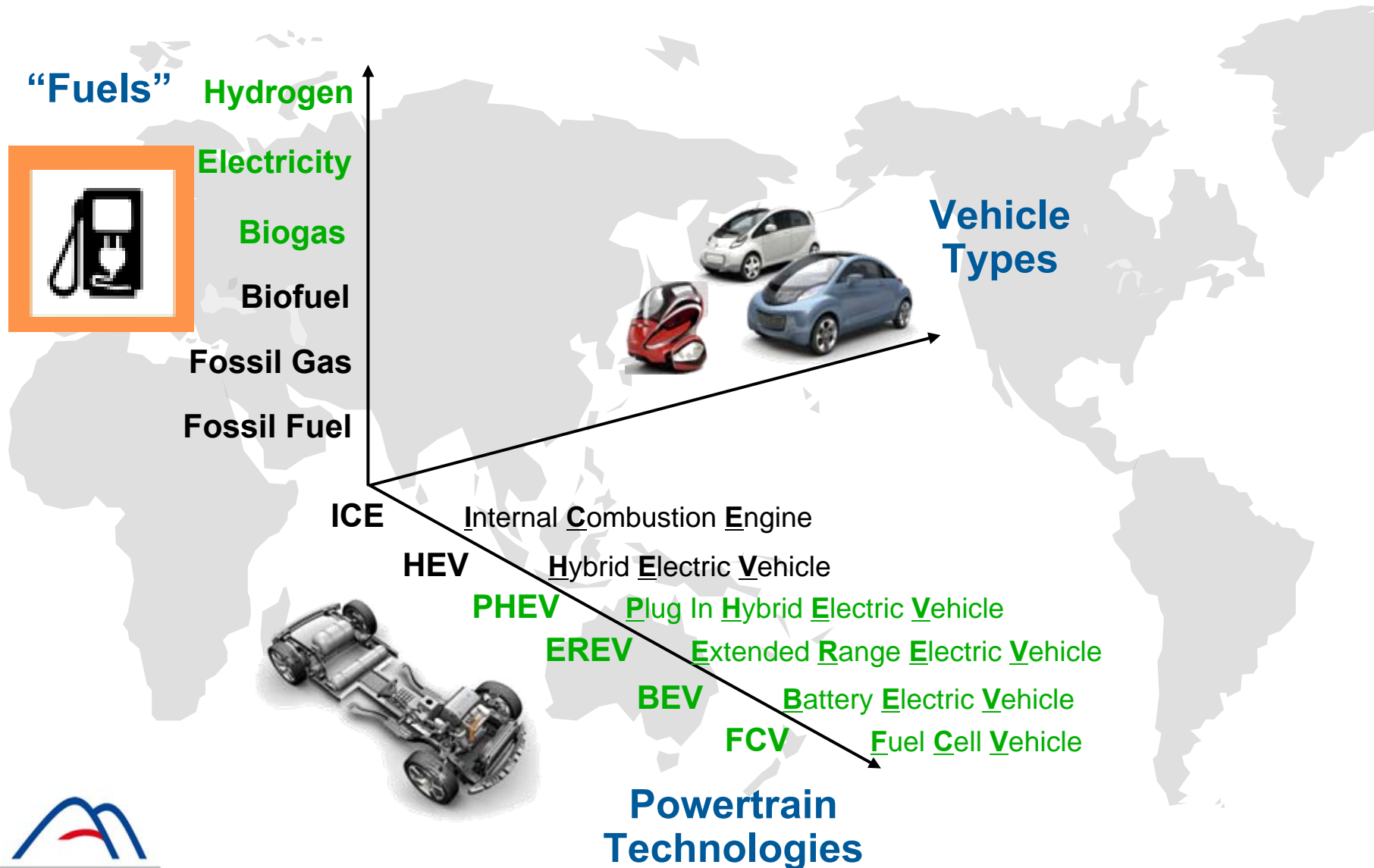

POWERTRAIN ELECTRIFICATION



- High battery capacity at low weight



Battery



IC Engine

- Variable valve lift
- Variable compression ratio
- Variable oilpump
-

Flexibility \approx Cost, Complexity & Risk

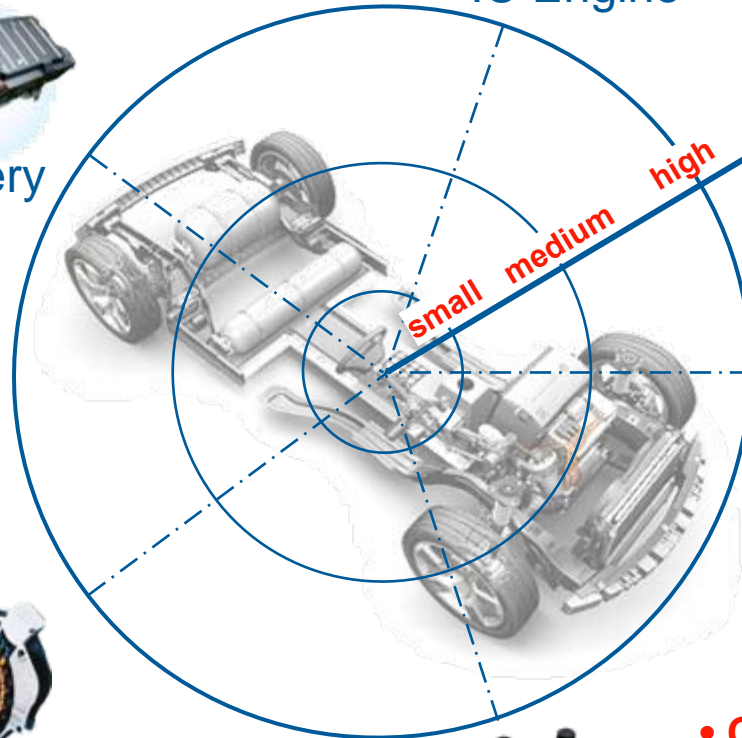

- High power / torque E-Motor



Electric Motor

- CVT
- DCT
- AT 8
-



Transmission

- Complex EMS
- Complex TMS
-



Control Strategy



FUTURE POWERTRAIN

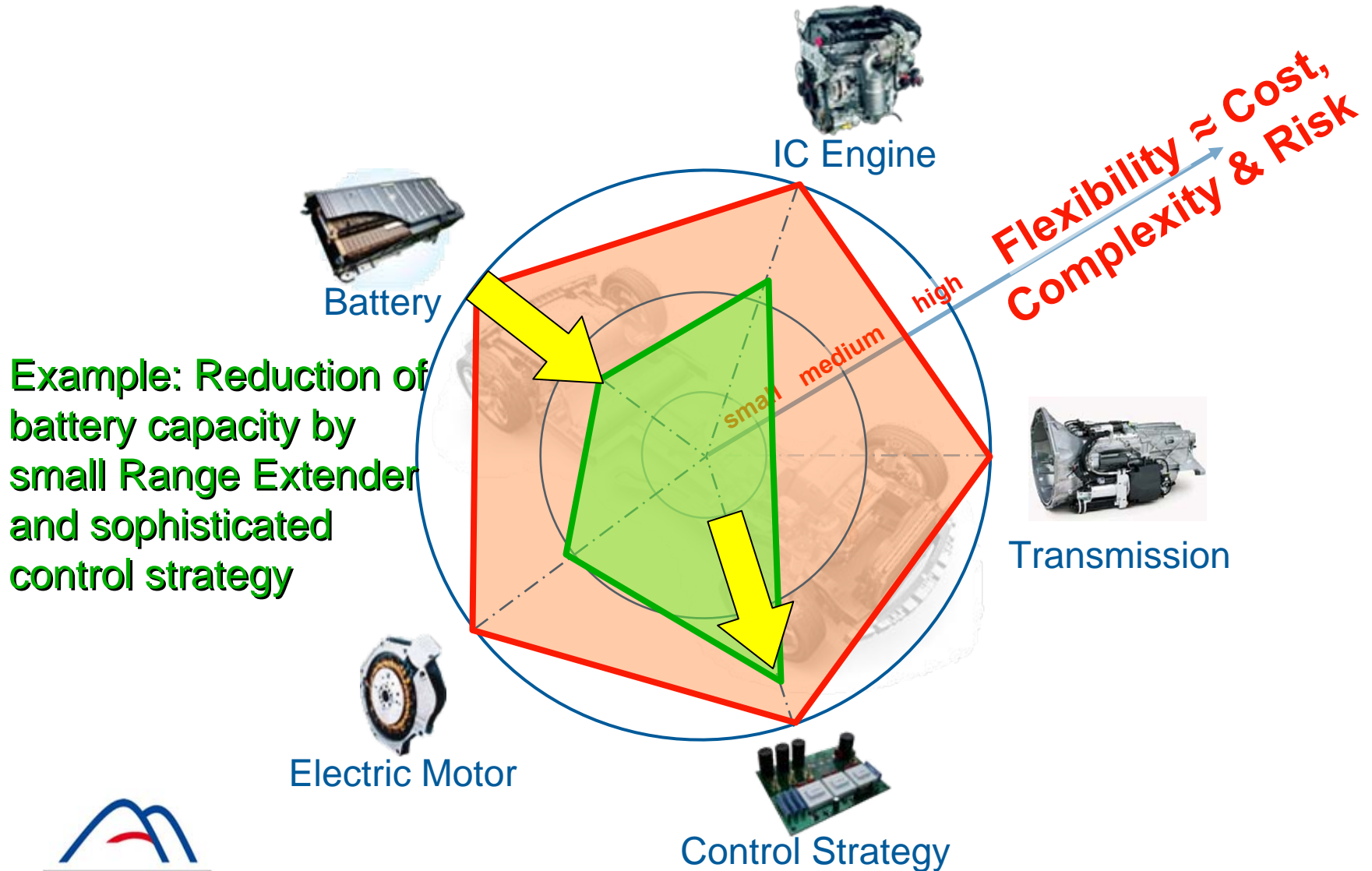

Example: Reduction of battery capacity by small Range Extender and sophisticated control strategy



POWERTRAIN ELECTRIFICATION PARALLEL HYBRID



Parallel Hybrid
ICE: 65 kW
E-Motor: 14 kW
Battery: 0,6 kWh

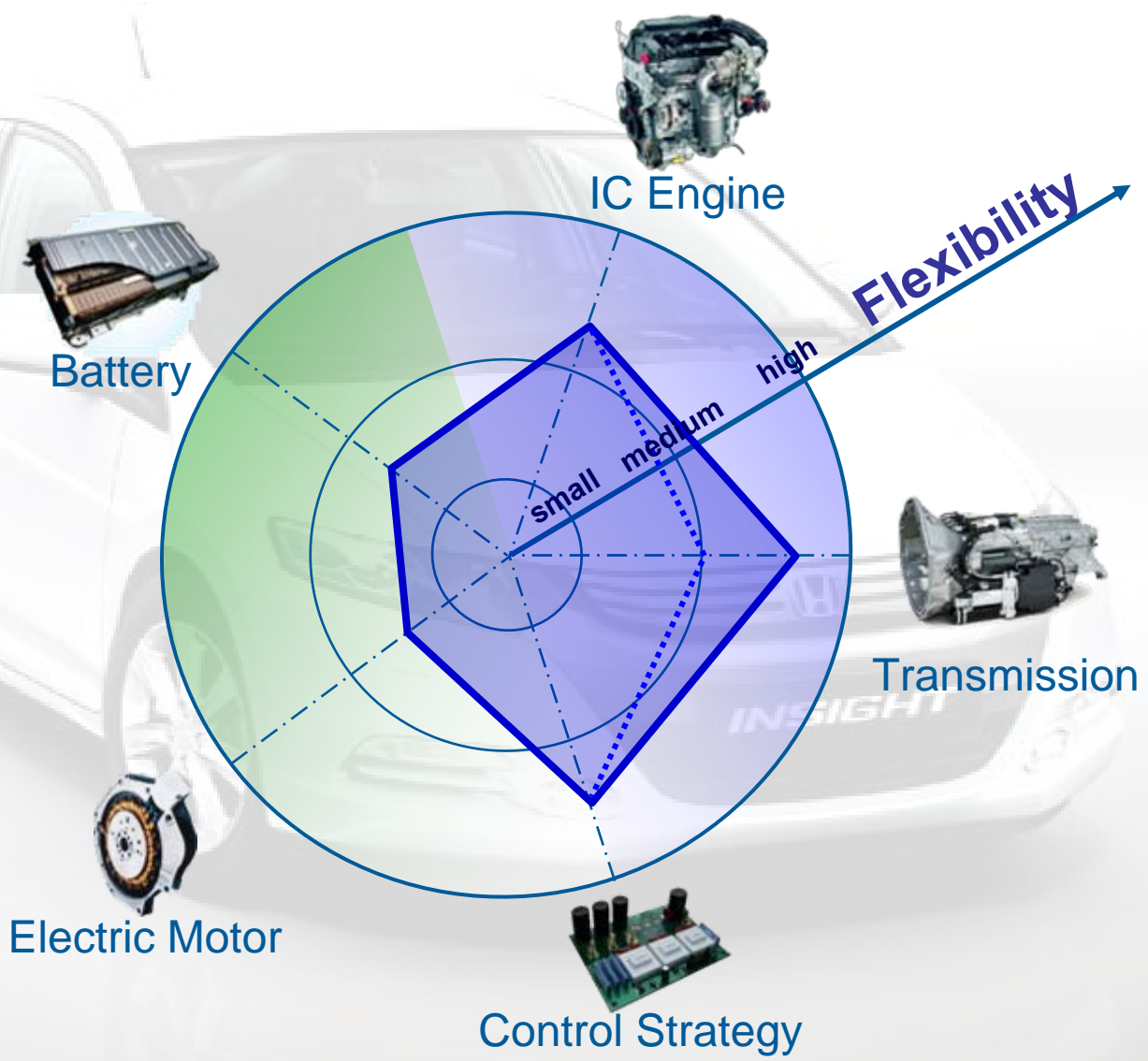

POWERTRAIN ELECTRIFICATION

POWERSPLIT HYBRID



Parallel Hybrid
ICE: 65 kW
E-Motor: 14 kW
Battery: 0,6 kWh

Powersplit Hybrid
ICE: 73 kW
E-Motor: 60 kW
Battery: 1,3 kWh

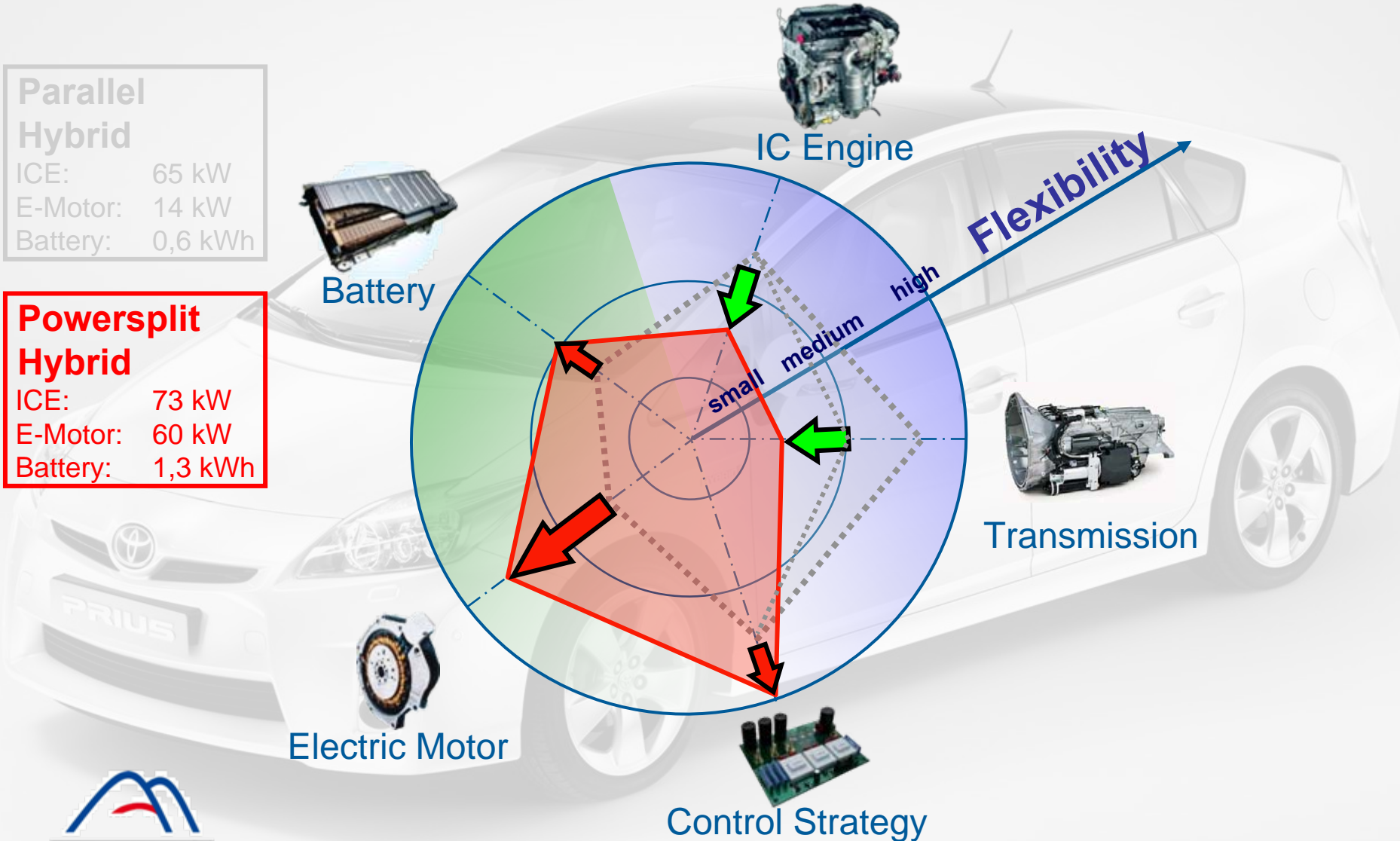

Automotive Summit
Brussels, Nov 10th, 2010

Foto: Toyota

POWERTRAIN ELECTRIFICATION SERIAL PLUG-IN HYBRID

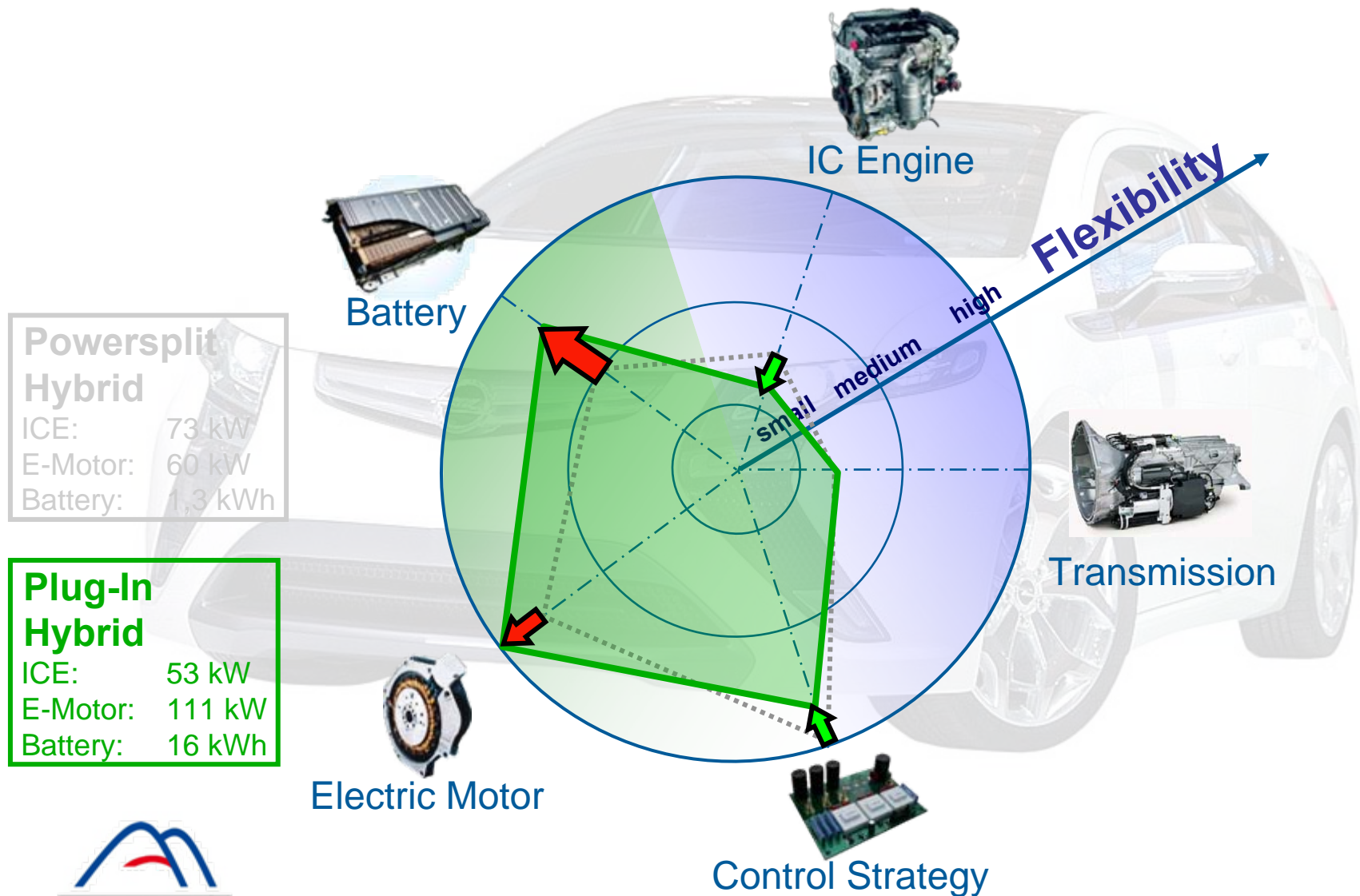

POWERTRAIN ELECTRIFICATION BATTERY ELECTRIC VEHICLE

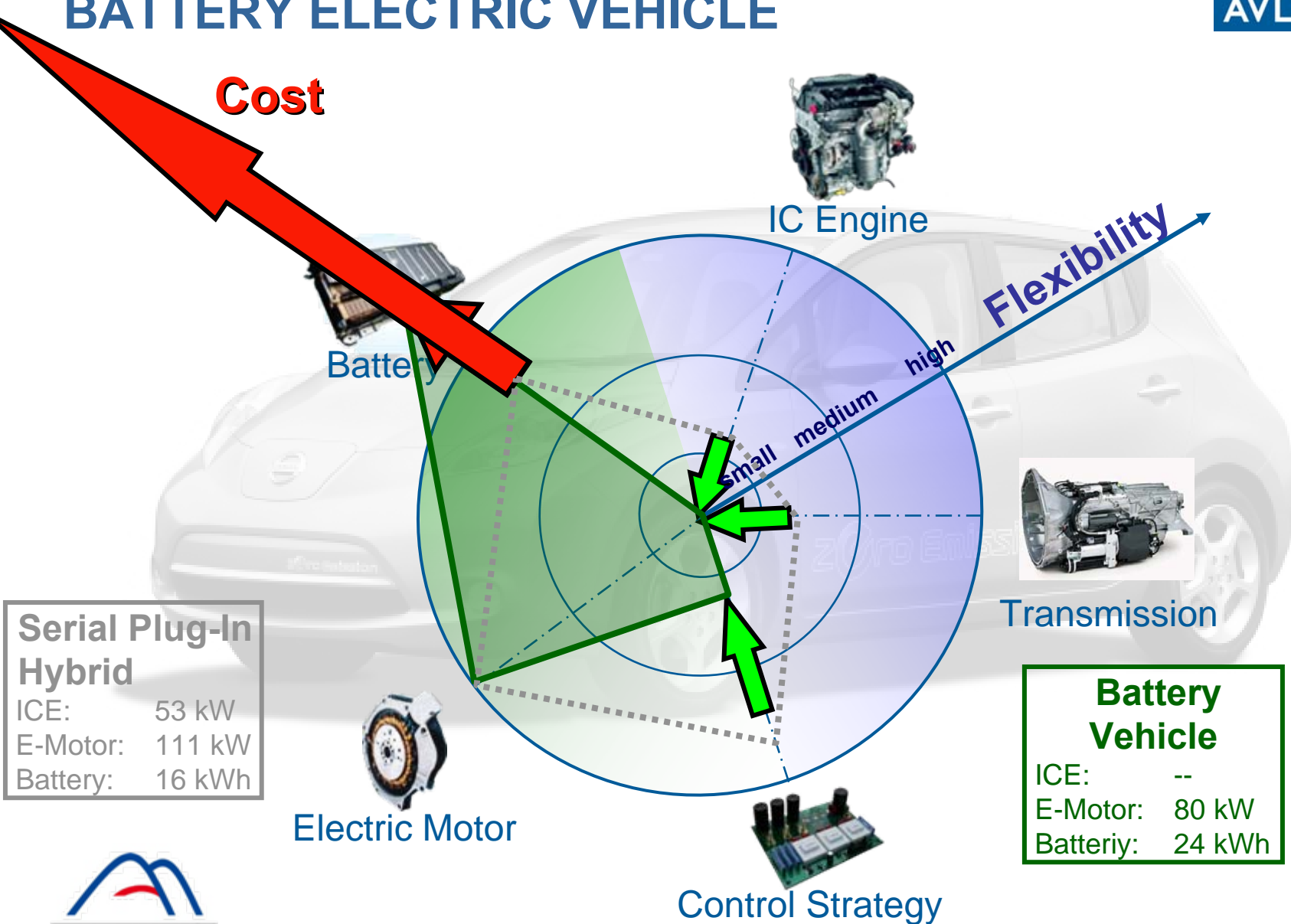

Serial Plug-In Hybrid	
ICE:	53 kW
E-Motor:	111 kW
Battery:	16 kWh

Battery Vehicle	
ICE:	--
E-Motor:	80 kW
Battery:	24 kWh

POWERTRAIN ELECTRIFICATION VARIETY OF DIFFERENT SYSTEMS



Parallel Hybrid
 ICE: 65 kW
 E-Motor: 14 kW
 Battery: 0,6 kWh

Powersplit Hybrid
 ICE: 73 kW
 E-Motor: 60 kW
 Battery: 1,3 kWh

Plug-In Hybrid
 ICE: 53 kW
 E-Motor: 111 kW
 Battery: 16 kWh

Battery Vehicle
 ICE: --
 E-Motor: 80 kW
 Battery: 24 kWh

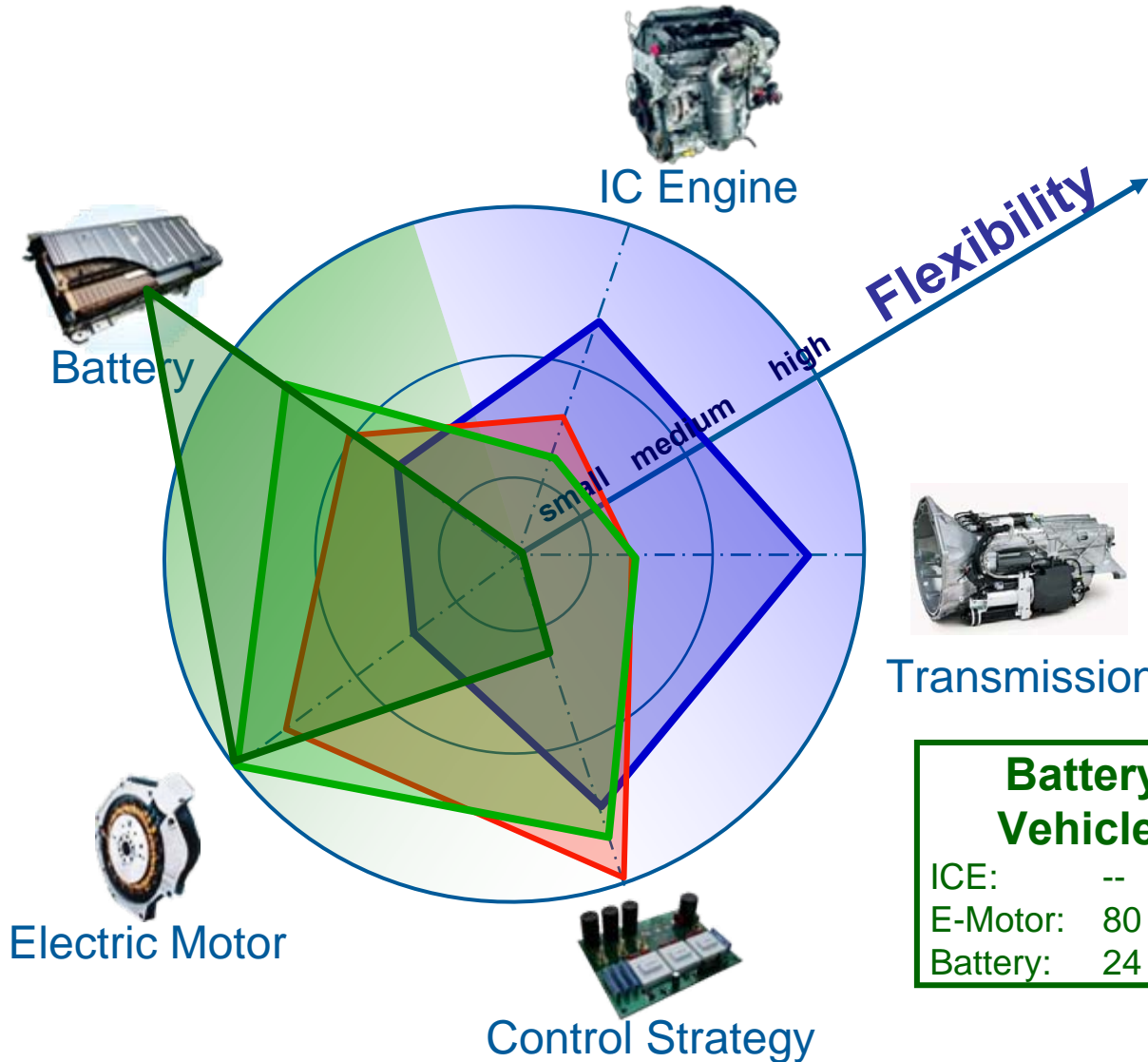

POWERTRAIN ELECTRIFICATION VARIETY OF DIFFERENT SYSTEMS



Parallel Hybrid	
ICE:	65 kW
E-Motor:	14 kW
Battery:	0,6 kWh

Powersplit Hybrid	
ICE:	73 kW
E-Motor:	60 kW
Battery:	1,3 kWh

Plug-In Hybrid	
ICE:	53 kW
E-Motor:	111 kW
Battery:	16 kWh

Battery Vehicle	
ICE:	--
E-Motor:	80 kW
Battery:	24 kWh

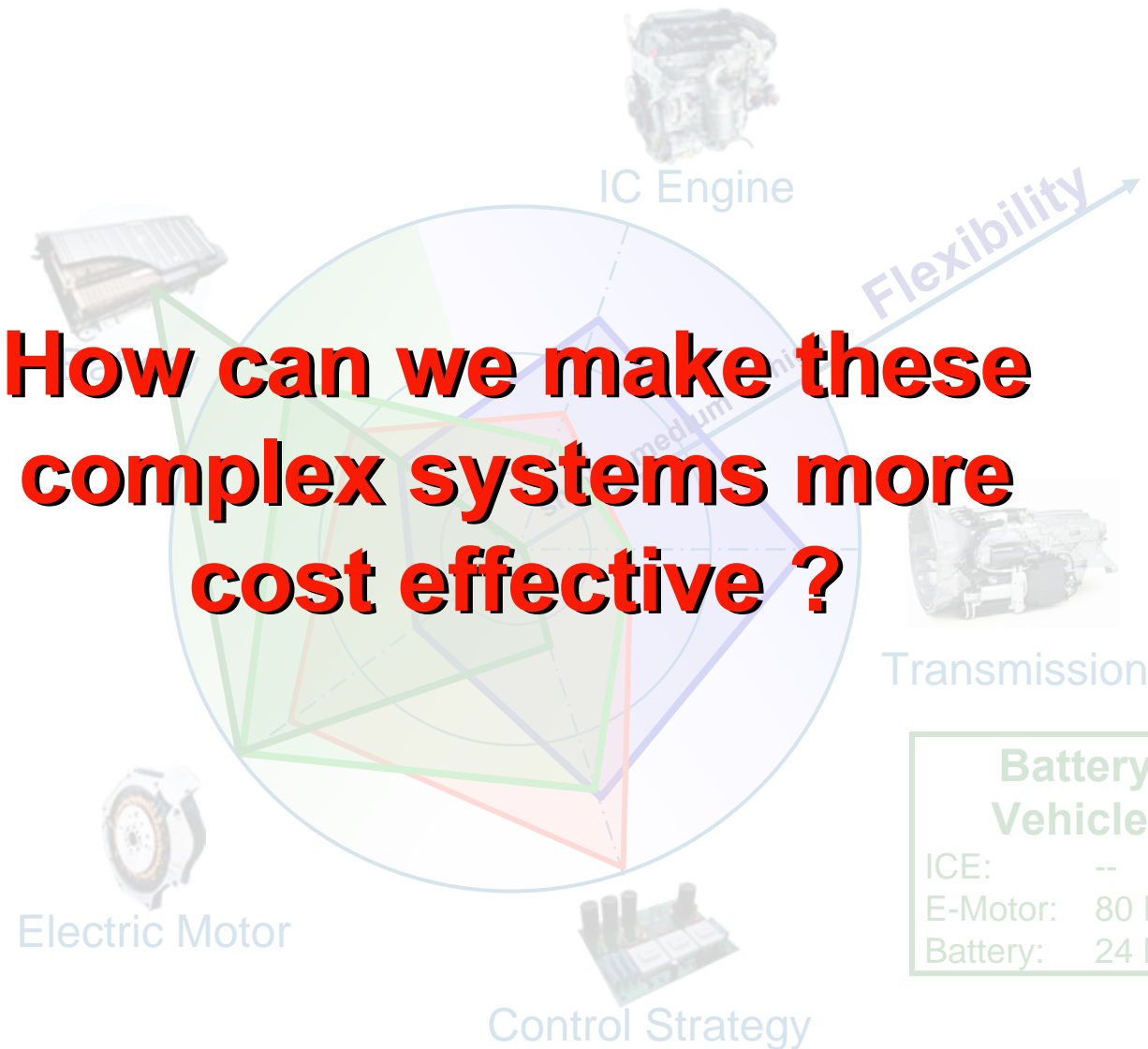

HYBRID EXAMPLES

MICRO HYBRID +ELECTRIC PRESSURE BOOST



Parallel Hybrid	
ICE:	65 kW
E-Motor:	14 kW
Battery:	0,6 kWh

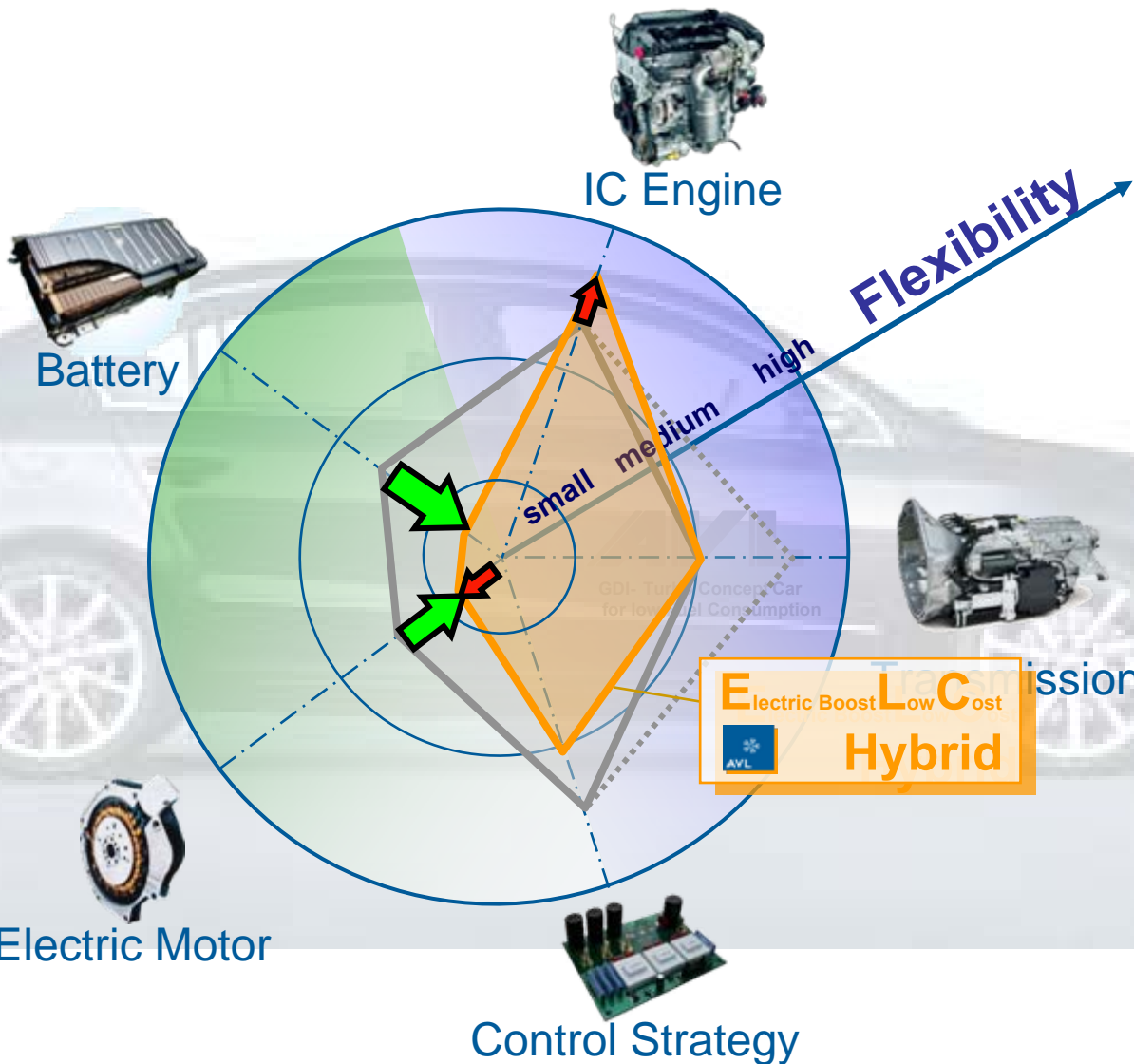

AVL ELECTRIC BOOST LOW COST HYBRID



- Micro Hybrid for provision of additional electric energy
- Utilisation of recuperated energy for enhanced transient torque (by E-boost) → enables longer drive ratio for improved FE
- Only minor impact on engine design and vehicle electric system (12 V)

Benefit: 1 + 1 = "2,2"

Cost: 1 + 1 = "2,0"



HYBRID EXAMPLES

MILD HYBRID +TURBOCHARGING



Parallel Hybrid	
ICE:	65 kW
E-Motor:	14 kW
Battery:	0,6 kWh

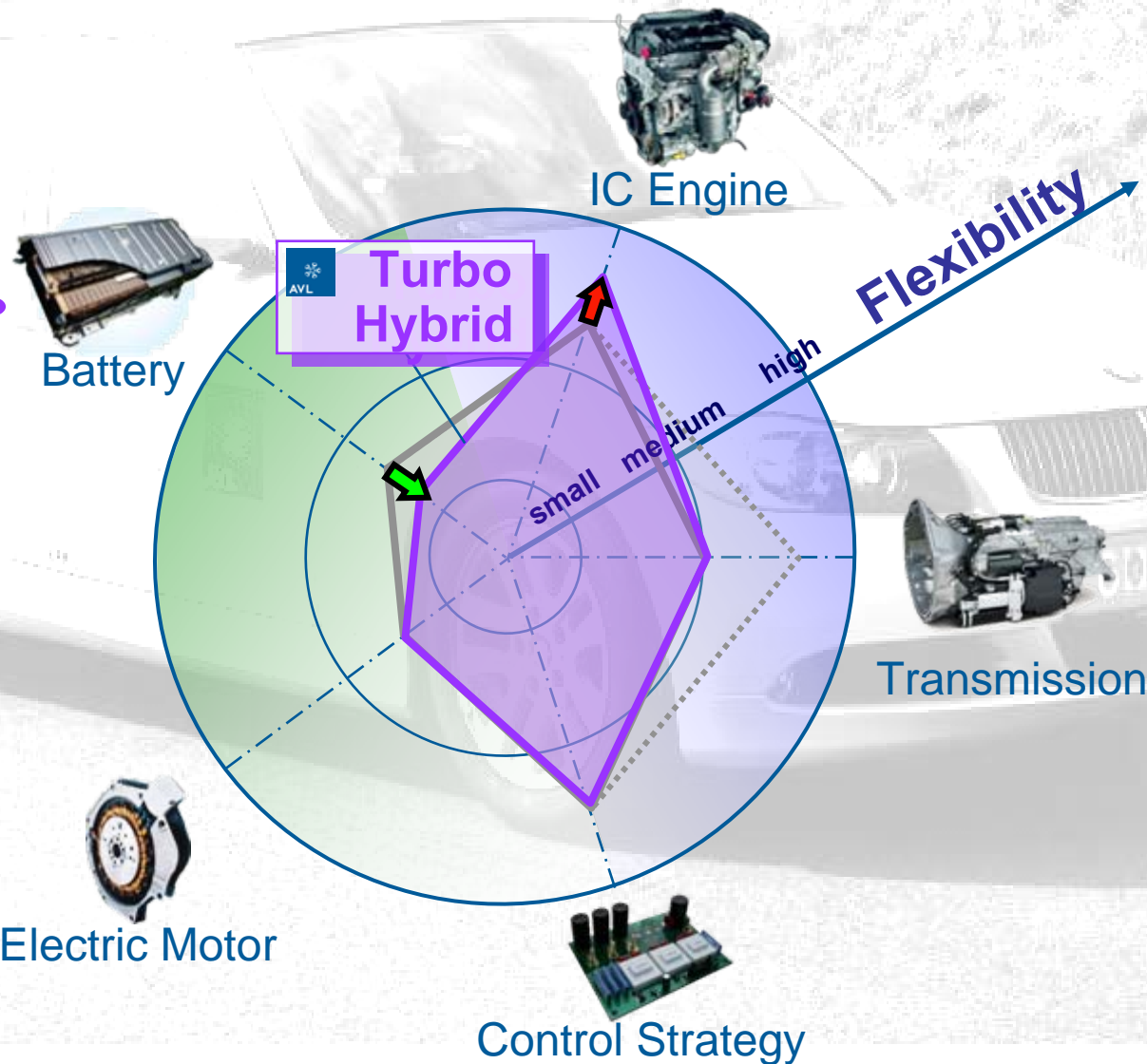

- Mild Hybrid 14 kW ISG as enabler for enhanced Downsizing + Downspeeding
- Recharging under worst case condition by overboost of ICE → enables minimised size of energy store
- Larger impact on powertrain design and vehicle electric system (390 V)

Benefit: $1+1 = \text{“2,1”}$

Cost: $1+1 = \text{“1,5”}$

REAL WORLD FUEL ECONOMY WITH HYBRID CONCEPTS - ECO DRIVING STYLE



Mid size sedans, 1550 kg, SI engines, Start / Stop, intelligent battery management,
Hybrid vehicles with system specific add-on weight

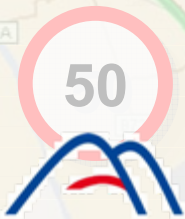
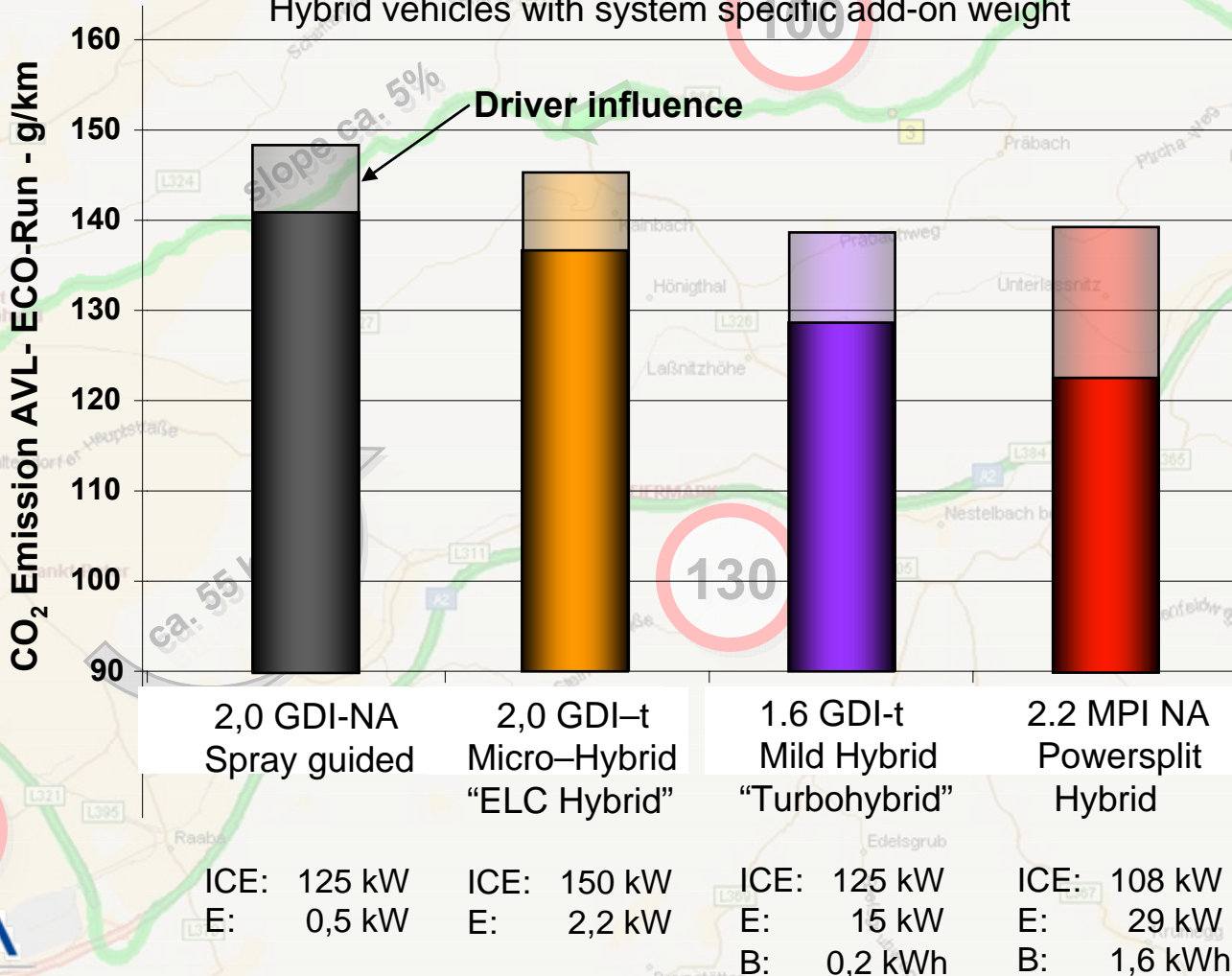

HYBRID EXAMPLES BATTERY VEHICLE VS. RANGE EXTENDER

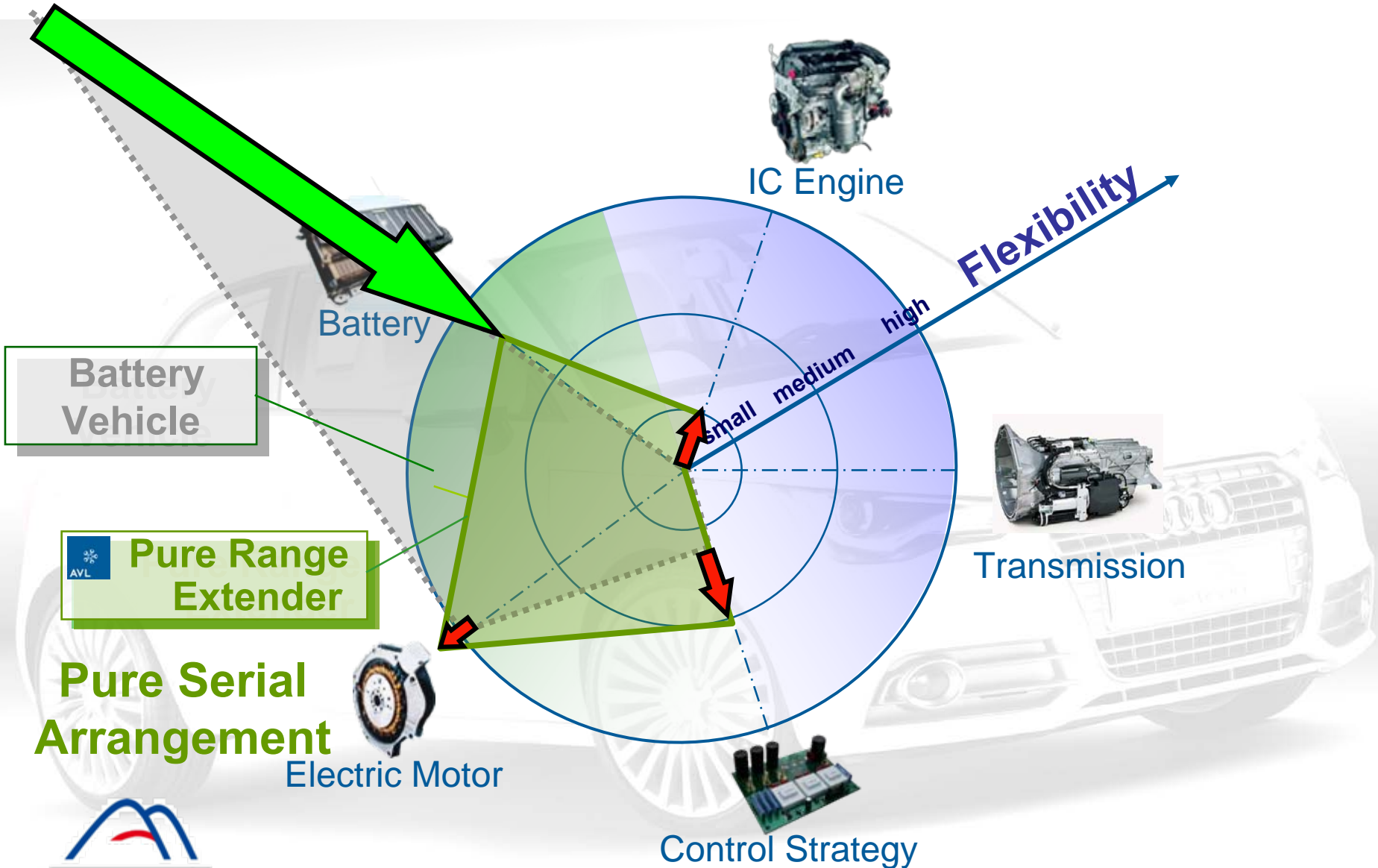

THE VEHICLE USAGE PROFILE DEFINES THE MOST EFFECTIVE ELECTRIFICATION APPROACH

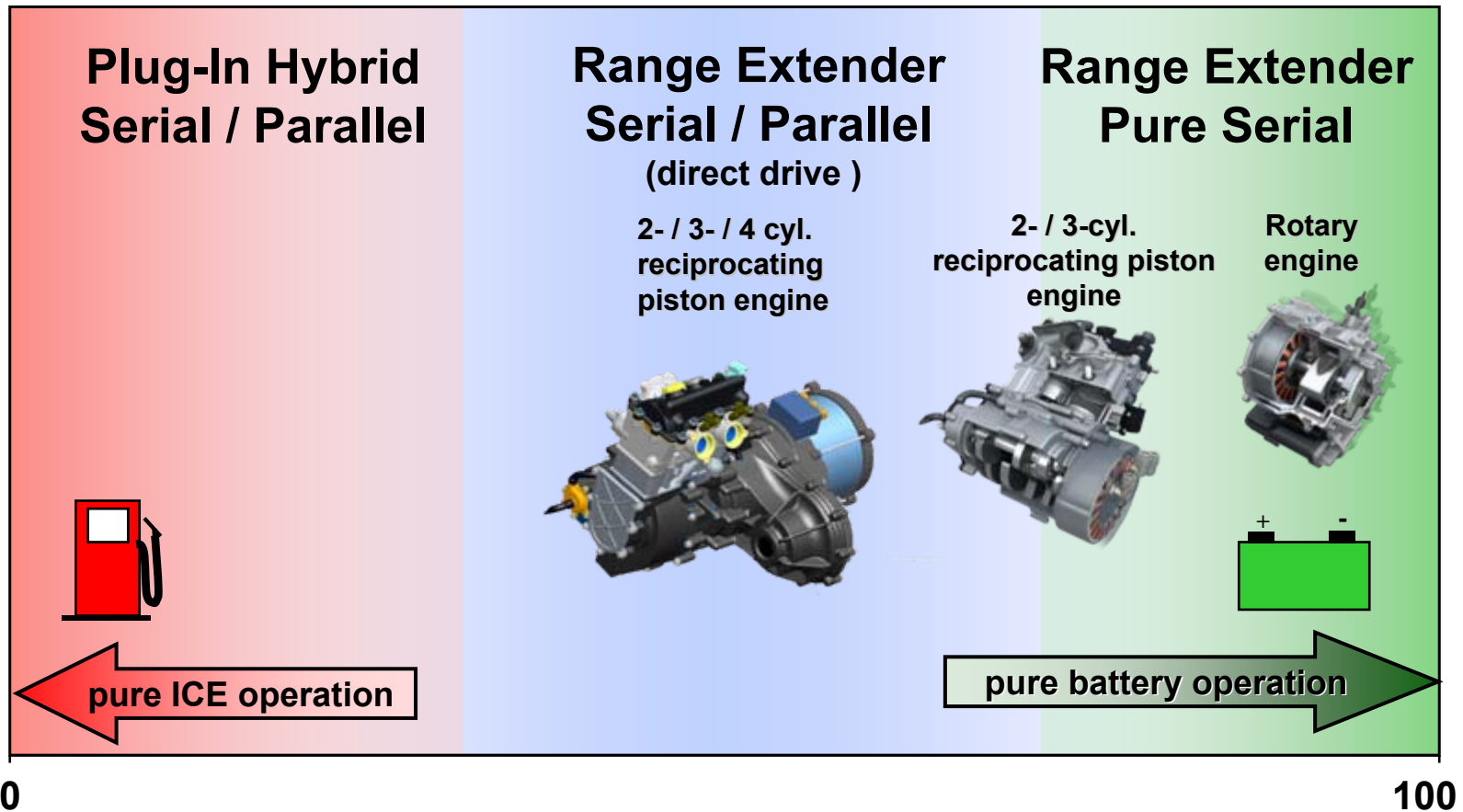

Share of energy from battery charged by the power grid - %



PURE RANGE EXTENDER PRIORITISATION OF TARGETS

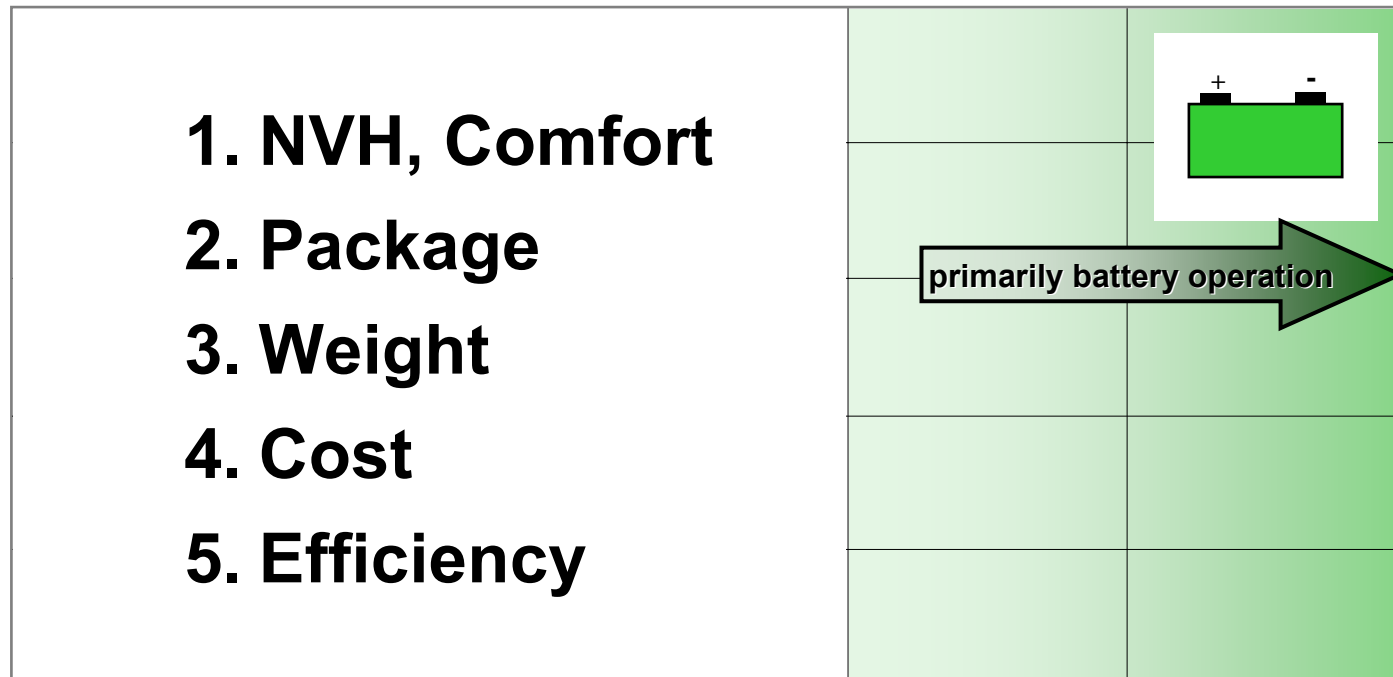

- ➔ **Compared to „Standard Powertrain“ completely changed requirements**
- ➔ **Application of unconventional combustion engines reasonable**

AVL 2-Cylinder RANGE EXTENDER

Focus on Cost and Efficiency

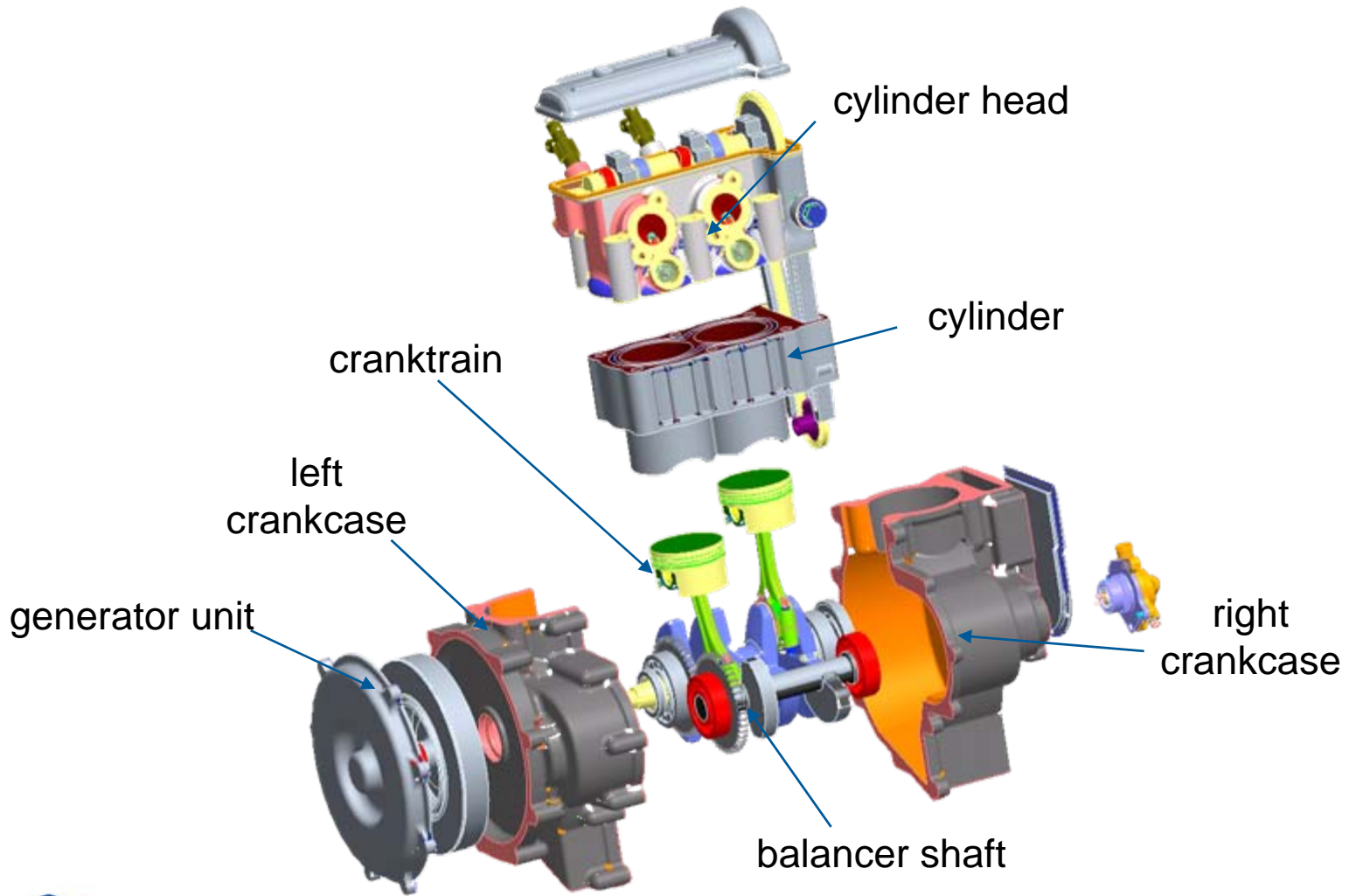

AVL PURE RANGE EXTENDER

Focus on NVH, Packaging and Weight



The highest integration depth of combustion engine and electric motor



AUDI A1 E-TRON with AVL RANGE EXTENDER

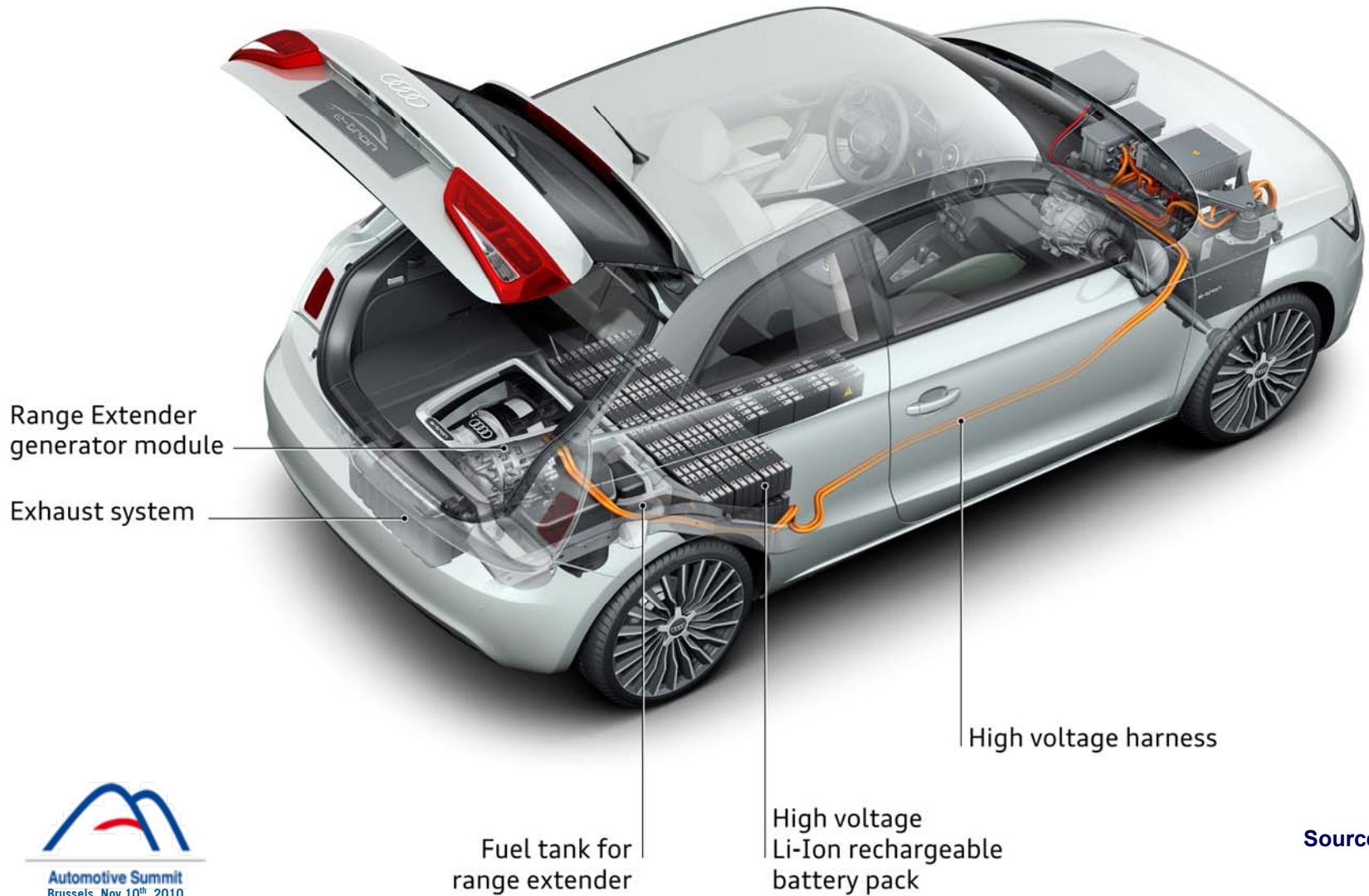

AUDI A1 E-TRON with AVL RANGE EXTENDER

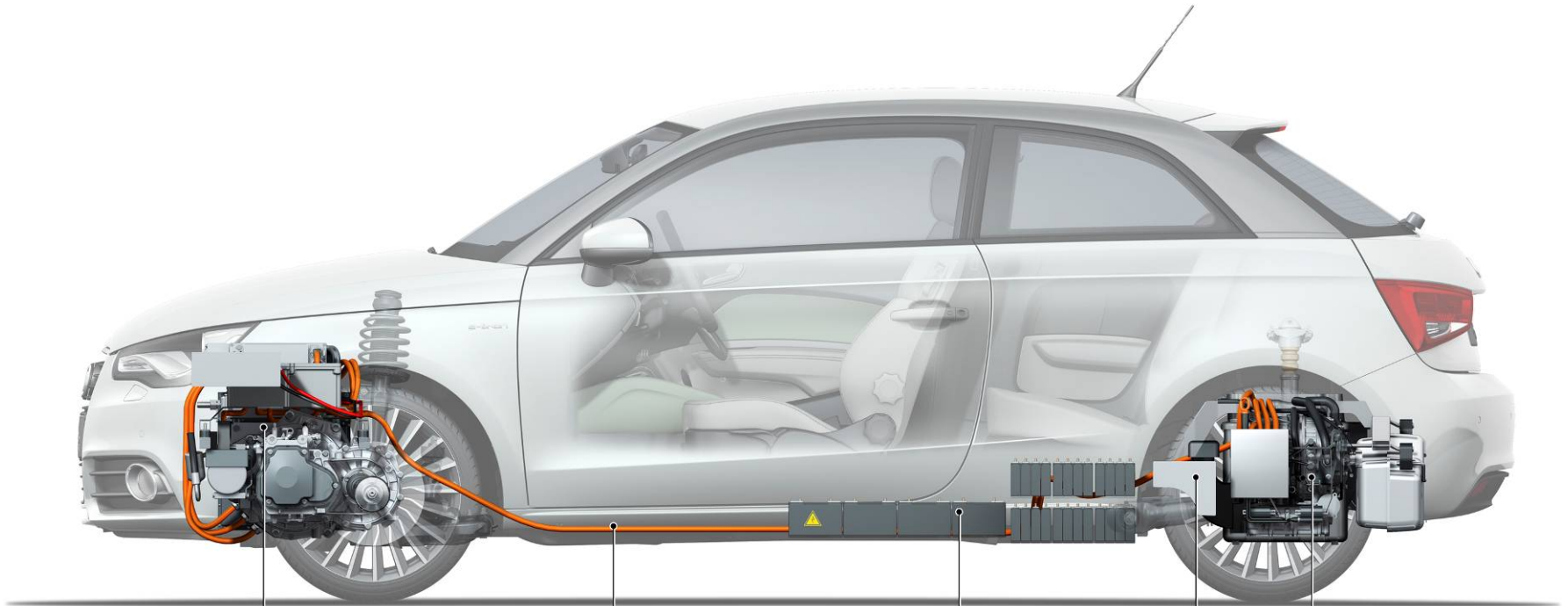

Electric traction motor

High voltage harness

High voltage
Li-Ion rechargeable
battery pack

Fuel tank for
range extender

Range Extender
generator module

Source: AUDI



Automotive Summit
Brussels, Nov 10th, 2010

SUMMARY



- The combustion engine is an enabler for an affordable electromobility without range constraints
- Powertrain electrification enables the combustion engine to be operated more fuel efficient
- Synergies between combustion engine, electric motor and battery can be utilized in various ways
→ larger differentiation of powertrain systems
- The competition of the electric vehicle is enhancing also the development on conventional powertrains

